

SK Series Backlash-free Torque limiters**Reliable Torque Overload Protection**

The trend in industry is to design and incorporate more automation into production processes. Machines are becoming more accurate, requiring a higher degree of precision. They are becoming faster, using servo and DC drive technology, and they are more rigid to withstand the dynamic loads necessary to increase capacity and productivity. Torque overloads caused by material jams, operator error, or a whole host of unforeseen reasons pose a significant threat to machine downtime.

Machine downtime in an automated production environment is very costly. Broken components, expensive technicians, and long lead times for custom components can make the difference between operating profitably or not. Torque overload couplings are an inexpensive insurance against downtime.

This catalog contains many different torque overload coupling designs. They all incorporate the patented **R+W** design principle. The couplings are all torsionally rigid with absolute zero backlash. The use of a patented **R+W** Torque Limiter will isolate the driving from the driven elements within a matter of milliseconds, once the torque reaches a preset overload value. Incorporating **R+W** Torque limiting couplings into modern machine design will help insure high productivity and higher profits.

Table of contents

Coupling designs	3
Overview of possible function systems	4/5
Torque limiter model SK 1 / SKP Single-position, multi-position, load holding, full disengagement versions	6/7
Torque limiter model SK 2 Single-position, multi-position, load holding, full disengagement versions	8
Torque limiter model SK 3 Single-position, multi-position, load holding, full disengagement versions	9
Torque limiter model SK 5 Single-position, multi-position, load holding, full disengagement versions	10/11
Accessories / Function description SK	12
Assembly instructions	13/14
Adjustment of the disengagement torque	15
Important additional information	16
Selection	17/18
Important additional information	19
Product range	20

Torque limiters

Areas of application

- Machine tools
- CNC machining centers
- Woodworking machines
- Automation equipment
- Textile machinery
- Industrial robots
- Sheet metal processing machines
- Printing + Converting machinery
- Servo + DC motor drives

Features

- Absolutely backlash-free and torsionally rigid (R+W patented principle)
- Compact, uncomplicated design
- Disengagement detection is achieved through indexing ring movement
- Low residual friction following disengagement
- Low moment of inertia
- Disengagement within msec

Possible versions

- Single position re-engagement
- Multi position
- Load holding
- Full disengagement

Models

Possible applications

Features

SK 1 / SKP

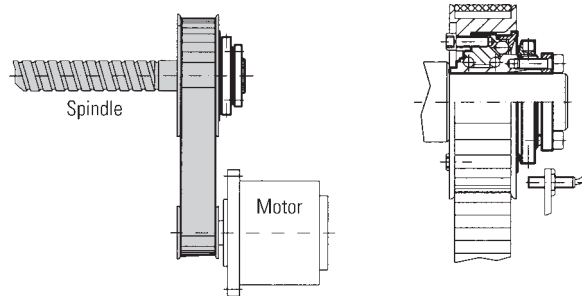

For pulley, sprocket, and gear applications for indirect drives

- Integral bearings for timing belt pulley or sprocket gear
- Compact, simple design
- Adjustable settings

SK 2

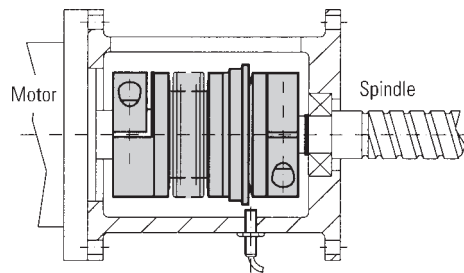

With clamping hub for direct drives

- Easy assembly
- Low moment of inertia
- Small installation space
- Compensates for shaft misalignment
- Adjustable settings

SK 3

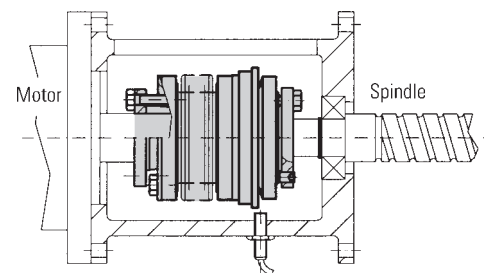

With conical clamp connection for direct drives

- High clamping forces
- High degree of operational dependability
- Compensates for shaft misalignment
- Adjustable settings

SK 5

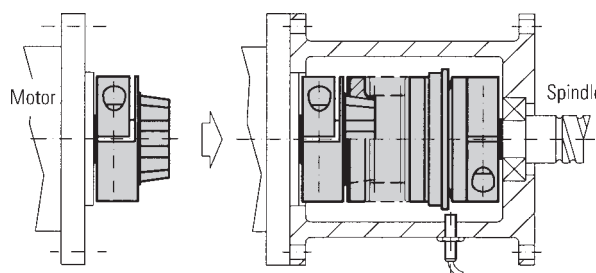

With clamping hub, press-fit version for direct drives

- Easy mounting and dismounting
- electrically and thermally insulated
- Compensates for shaft misalignment
- Adjustable settings

PATENTED BACKLASH -

OVERVIEW OF POSSIBLE

Single-position re-engagement



Standard version

- After the overload has been removed, the coupling will reengage precisely 360 ° from the original disengagement position.
- Signal at overload
- Suitable for use, in machine tools, packing machines and automation systems and other applications requiring precise timing.

Load holding Version



- In the event of a torque overload, the drive and driven elements are not separated and are only allowed limited rotation.
- Guaranteed to hold the load and signal an overload.
- Automatic engagement after the torque level has dropped.
- Signal at overload to detect with mechanical switch or proximity sensor.
- Suitable for use, on presses, load lifting equipment or on any applications where the drive and driven elements cannot be separated.

FREE TORQUE LIMITERS

Every model in this catalog is available in all 4 versions.

FUNCTION SYSTEMS

Multi-position coupling



- Coupling re-engages at multiple set angular intervals.
- Immediate availability of the machine as soon as the overload has been removed.
- Signal at overload with mechanical switch or proximity sensor
- Standard engagement every 60°
- Engagement after 30, 45, 90 and 120 degrees optional.

Full disengagement



- Permanent separation of drive and driven loads in the event of a torque overload.
- No residual friction
- Signal at overload with mechanical switch or proximity sensor
- Rotating elements slow down freely
- Coupling can be re-engaged manually (Engagement every 60°)
- Suitable for applications with high speeds
- **Coupling can be disengaged manually. Please contact R+W.**

Model SK 1 / SKP

BACKLASH FREE TORQUE LIMITER

with conical clamp, or as a pure keyway connection

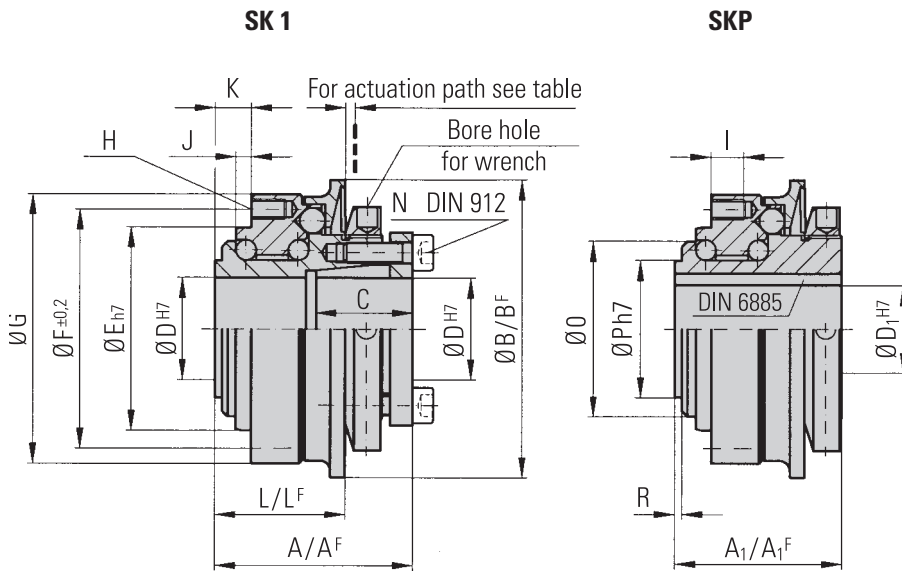

Material

High-strength steel

Design

Model SK 1 with conical clamp

Model SKP with pure keyway connection

Temperature range: -30° C to +120° C

Temperature peaks up to + 150° C

Speed after disengagement: Dependent on set disengagement torque

Backlash: Absolutely backlash-free as a result of the frictional clamp connection and the patented R+W principle

Service life: These couplings are maintenance-free and have extreme service life as long as all the performance units are not exceeded.

Optional clamping hub available upon request

Optional sealed version for wash down and foodservice application.

See page 16

TECHNICAL INFORMATION

Single-position • Multi-position • Load holding

Series	Adjustable range possible from -to (Nm)	Overall length without screws heads (mm)	Overall length (mm)	Outer diameter of actuation ring (mm)	Length of taper (mm)	Inner diameter from Ø to Ø H7 (mm)	Inner diameter from Ø to Ø H7 (mm)	Centering diameter h7 bolt circle diameter up to Ø H7 (mm)	Flange diameter h7 (mm)	Flange diameter ±0.2 (mm)	6 x thread (mm)	Thread depth +1 (mm)	Centering length - 0.2 (mm)	6 x screws DIN 912 (mm)	Tightening torque (mm)	Moment to inertia (Nm)	Approx. weight (kg)	Actuation path (mm)					
	T _{KN}	A	A ₁	B	C	D	D ₁	E	F	G	H	I	J	K	L	N	O	P	R	J _{ges}			
15	5-20 or 12-35	40	34	55	19	8-22	19	40	47	53	M4	6	3	8	27	M4	4	35	27	2.5	0.15	0.4	1.5
30	10-25 or 20-55	50	43	65	22	12-22	24	47	54	63	M5	8	5	11	35	M5	4	42	32	2.5	0.25	0.7	1.5
60	10-30 or 25-80	54	46	73	27.5	12-29	30	55	63	72	M5	9	5	11	37	M5	7	49	39	2.5	0.50	1.0	1.7
150	20-70 45-150 80-225	58	48.5	92	32	15-37	38	68	78	87	M6	10	5	12	39	M6	12	62	50	2.5	1.60	1.3	1.9
200	30-90 60-160 140-280	63	53	99	32	20-44	44	75	85	98	M6	10	5	12	44	M6	14	67	55	3	2.70	2.0	2.2
300	100-200 150-240 220-440	70	57	120	41	25-56	52	82	98	112	M8	10	6	15	47	M8	18	75	65	3	5.20	3.0	2.2
500	80-200 200-350 320-650	84	71.5	135	41	25-56	58	90	110	128	M8	12	9	21	59	M8	25	84	72	4	8.60	4.0	2.2
800	400-650 500-800 650-950	95	80	152	49	30-60	62	100	120	140	M10	15	10	19	67	M10	36	91	75	4	20	5.5	2.2
1500	600-800 700-1200 1000-1800	109	93	174	61	35-70	73	125	148	165	M12	16	12	25	82	M12	70	112	92	4.5	31.5	10	3.0
2500	1500-2000 or 2000-2500	146	137	240	80	50-100	95	168	202	240	M16	24	20	35	108	M16	120	154	130	6	210	28	3

A^F, B^F, L^F and further technical information for full disengagement coupling see page 7.

Model SK 1

BACKLASH FREE TORQUE LIMITER IN MINIATURE DESIGN (FROM 0.2 - 12 Nm)

SK 1

with clamping hub

SKP**

with a pure key connection

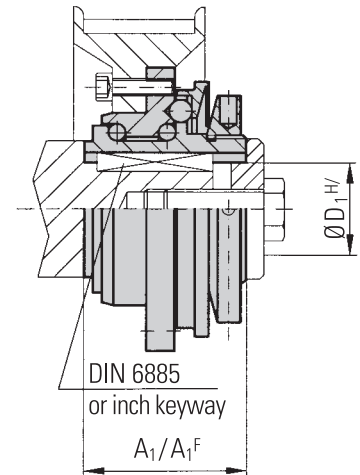
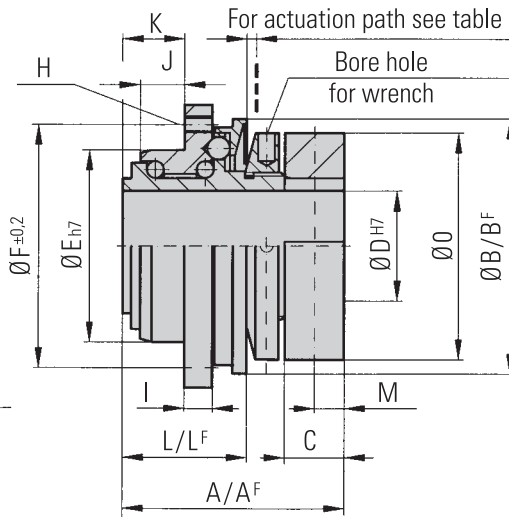
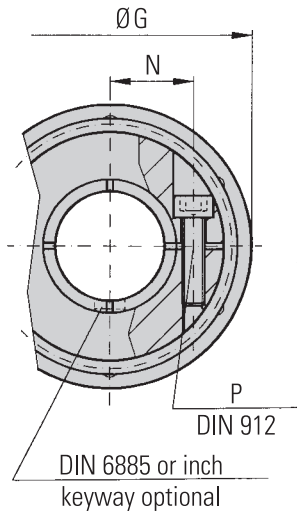

Series	Adjustable range possible from - to (Nm) (approx. values)	Overall length (mm)	Overall length (mm)	Outer diameter of actuation ring (mm)	Clamping fit length (mm)	Inner diameter from Ø to Ø H7 (mm)	Inner diameter from Ø to Ø H7 (mm)	Centering diameter h7 (mm)	Hole circle diameter h7 (mm)	Flange diameter ± 0.2 (mm)	Thread (mm)	Thread length (mm)	Centering length - 0.2 (mm)	Distance between centers (mm)	1x screw DIN 912 (mm)	Tightening torque in (Nm)	Moment of inertia (10 ³ kgm ²)	Approx. weight (g)	Actuation path (mm)				
	T _{KN}	A	A ₁	B	C	D	D ₁	E	F	G	H	I	J	K	L	M	N	O	P	J _{ges}			
2	0.2-1.5 0.5-2.2 1.5-3.5	28	20	29	8	4-12	4-10	22	28	32	4x M 2.5	4	3.5	6	15	4	8	25	M3	2	0.02	65	0.8
4.5	1.3 2-4.5 3-7	32	22	35	11	5-14	5-12	25	35	40	6x M 2.5	4	5	8	17	5	10	32	M4	2.5	0.05	120	0.8
10	2-6 4-12 7-18	39	28	45	11	6-20	6-16	34	43	50	6x M 3	5	8	11	22	5	15	40	M4	4.5	0.7	220	1.2

smaller sizes on request

Supplemental technical information for full disengagement version

Please note the following changes of dimensions and adjustment ranges

Dimension	Series	2	4,5	10	15	30	60	150	200	300	500	800	1500
A ^F		28	32	39	40	50	54	58	63	73	88	95	117
A ₁ ^F		20	22	28	34	43	46	49	53	60	75	90	107
B ^F		32	42	51.5	62	70	83	98	117	132	155	177	187
L ^F		16	18	23	27	37	39	40	42	51,5	62	75	91
Adjustment range from - to (Nm)		0.5-2	2.5-4.5	4-10	7-15	8-20 16-30	10-30 20-40 30-60	20-60 40-80 80-150	80-140 oder 130-200	120-180 oder 160-300	50-150 100-300 250-500	200-400 oder 450-850	1250-1500

Ordering specifications:

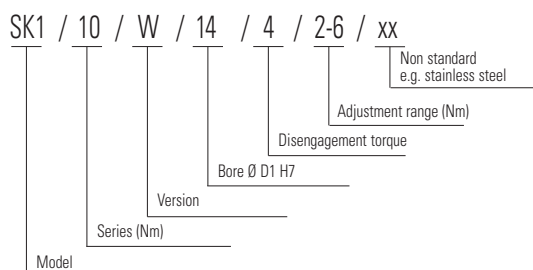

Possible versions

- W = Single-position engagement (standard)
- D = Multi-position engagement
- G = Load holding
- F = Full disengagement

Radial load capacity

For the maximum permissible radial load capacity for all SK 1 / SKP models, see installation instructions on page 14

Model SK 2

BACKLASH FREE TORQUE LIMITER

with clamping hub

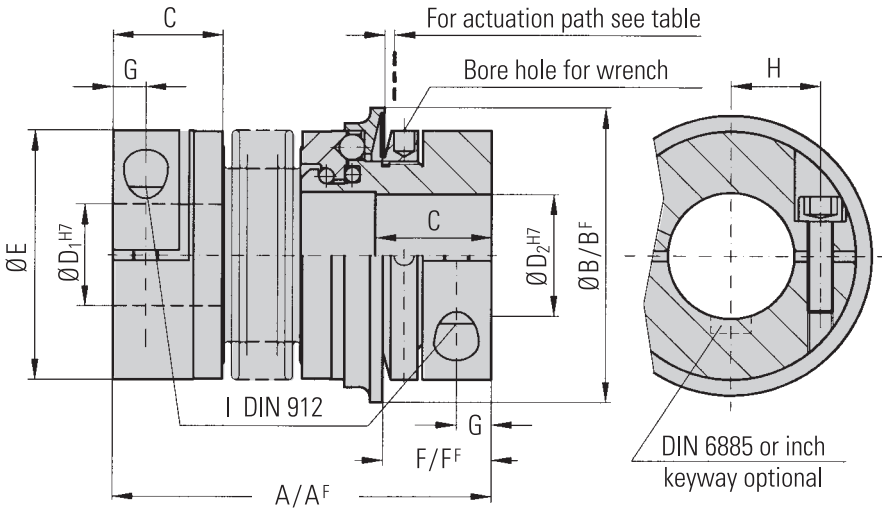

Material:

Bellows made of highly elastic stainless steel
 Safety section: High strength hardened steel
 Hub material: up to series 80 aluminium
 from series 150 steel

Design:

With a single radial clamping screw per hub DIN 912

Temperature range: -30° C to + 120° C

Speed after disengagement: Dependent on set disengagement torque

Backlash: Absolutely backlash free as a result of the frictional clamp connection and the patented R+W principle

Service life: These coupling are maintenance free and have extreme service life as long as the performance limits are not exceeded.

Ordering specifications: see page 11

Optional sealed version for wash down and foodservice application. See page 16.

TECHNICAL INFORMATION

Single-position • Multi-position • Load holding • Full disengagement

Series	Adjustable range possible from -to		Adjustable range (full disengagement) (Nm) (approx. values)		Adjustable range (full disengagement) (Nm) (approx. values)		Overall length (mm)	Outer diameter (full disengagement) (mm)	Outer diameter of actuation ring (mm)	Fit length (mm)	Inner diameter from Ø to Ø H7 (mm)	Outer diameter of coupling (mm)	Distance (full disengagement) (mm)	Distance between centers (mm)	DIN 912 screws (mm)	Tightening torque (mm)	Approx. weight (mm)	Moment of inertia (mm)	Torsional stiffness (Nm)	Lateral stiffness (kg)	Angular misalignment (10 ³ kgm ²)	Lateral misalignment (10 ³ Nm/rad)	Actuation path (mm)	
	T _{KN}	T _{KN}	A	A ^F	B	B ^F																		C
2	0.2-1.5 or 0.5-2	0.5-2	46	46	29	32	13	4-12	25	13	12	4	8	M3	2	0.07			0.01	2.8	0.15	1	40	0.8
			51	51															0.01	2.1	0.20	1.5	30	
4.5	1-3 or 3-6	2.5-4.5	57	57	35	42	16	5-14	32	15	14	5	10	M4	2.5	0.2			0.02	7	0.20	1.5	290	0.8
			65	65															0.02	5	0.25	2	45	
10	2-6 or 4-12	4-10	65	65	45	51.5	16	6-20	40	17	16	5	15	M4	4.5	0.3			0.06	9	0.20	1.5	280	1.2
			74	74															0.07	9	0.30	2	145	
15	5-20	7-15	75	75	55	62	22	10-26	49	19	19	6.5	17	M5	8	0.4			0.10	20	0.15	1	475	1.5
			82	82															0.15	15	0.20	1.5	137	
30	10-25 or 20-40	8-20 or 16-30	87	87	65	70	27	12-30	55	24	22	7.5	19	M6	15	0.6			0.27	39	0.20	1	900	1.5
			95	95															0.32	28	0.25	1.5	270	
60	10-30 or 25-80	20-40 or 30-60	102	102	73	83	31	15-32	66	30	29	9.5	23	M8	40	1.0			0.75	76	0.20	1	1200	1.7
			112	112															0.80	55	0.25	1.5	420	
80	20-70 or 30-90	20-60 or 40-80	115	117	92	98	35	19-42	81	31	31	11	27	M10	50	2.0			1.80	129	0.20	1	920	1.9
			127	129															1.90	85	0.25	1.5	290	
150	40-170	80-150	116	118	92	98	35	19-42	81	31	30	11	27	M10	70	2.4			2.50	175	0.20	1	1550	1.9
			128	130															2.80	110	0.25	1.5	435	
200	30-90 60-160 120-240	80-140 or 130-200	128	131	99	117	40	24-45	90	35	33	12.5	31	M12	120	3.0			3.30	191	0.25	1.5	2040	2.2
			140	143															3.50	140	0.30	2	610	
300	100-200 150-240 200-320	120-180 or 180-300	139	142	120	132	42	30-60	110	35	35	13	39	M12	130	4.0			6.50	501	0.25	1.5	3750	2.2
			153	156															7.00	295	0.30	2	1050	
500	80-200 200-350 300-500	60-150 100-300 250-500	163	167	135	155	51	35-60	123	45	43	17	41	M16	200	8.5			13.00	510	0.30	2	2500	2.2
			177	181															17.00	500	0.35	2.5	840	

A^F, B^F, F^F = full disengagement

(smaller sizes on request)

Caution! If the setted torque exceeds the series torque please contact the manufacturer.

Model SK 3

TORQUE LIMITER

with tapered clamp connection

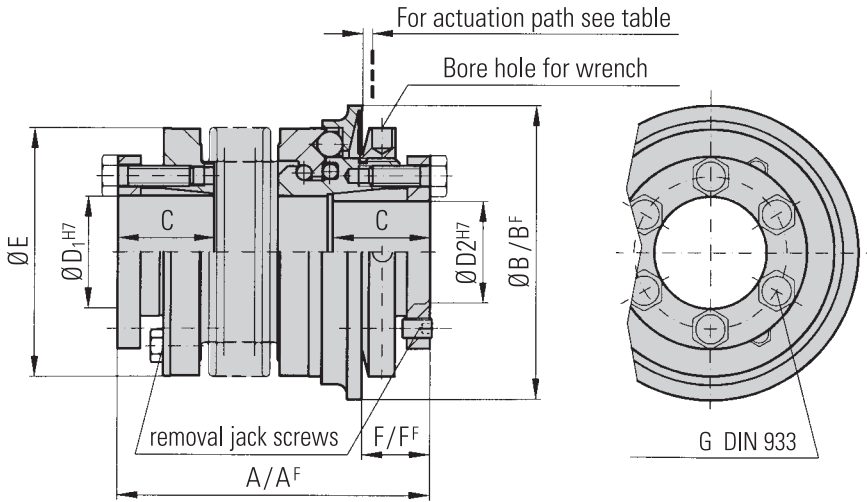

Material:

Bellows made of highly elastic stainless steel
Safety section: High strength hardened steel.
Hub material: Steel

Structure:

With slitted tapered conical sleeves and removal jack screws

Temperature range: -30° C to +120 ° C

Speed after disengagement: Dependent on set disengagement torque

Backlash: Absolutely backlash free as a result of the frictional clamp connection and the patented R+W principle

Service life: These coupling are maintenance free and have extreme service life as long as the performance limits are not exceeded.

Ordering specifications: see page 11

Optional sealed version for wash down and foodservice application. See page 16.

TECHNICAL INFORMATION

Single-position • Multi-position • Load holding • Full disengagement

Series	Adjustable range possible from - to	Adjustable range possible from - to (Nm) (approx. values)	Overall length	Outer diameter of actuation ring (mm)	Outer diameter of actuation ring (full disengagement) (mm)	Fit length	Inner diameter from Ø to Ø H7 (mm)	Outer diameter of coupling (mm)	Distance (mm)	Distance (full disengagement) (mm)	6x DIN 933 screws	Tightening torque	Approx. weight	Moment of inertia	Torsional stiffness (Nm)	Lateral stiffness (kg)	Lateral misalignment (10 ⁻³ Nm/rad)	Angular misalignment (degrees)	Lateral spring stiffness (N/mm)	Actuation path (mm)
	T _{KN}	T _{KN}	A	A ^F	B	B ^F	C	D ₁ / D ₂	E	F	F ^F	G	J _{ges.}	C _T						
15	5-20	7-15	62	62	55	62	19	10-22	49	13	13	M4	4	0.3	0.10	20	0.15	1	475	1.5
			69	69											0.15	15	0.20	1.5	137	
30	10-25 or 20-40	8-20 or 16-30	72	72	65	70	22	12-23	55	16	14	M5	4	0.4	0.28	39	0.20	1	900	1.5
			80	80											0.30	28	0.25	1.5	270	
60	10-30 or 25-80	20-40 or 30-60	84	84	73	83	27	12-29	66	18	17	M5	7	1.2	0.75	76	0.20	1	1200	1.7
			94	94											0.80	55	0.25	1.5	420	
80	20-70 or 30-90	20-60 or 40-80	92	92	92	98	32	15-37	81	20	18	M6	10	2.3	1.80	129	0.20	1	920	1.9
			104	104											1.90	85	0.25	1.5	290	
150	20-70 45-150 80-200	80-150	93	93	92	98	32	15-37	81	20	18	M6	12	2.3	1.90	175	0.20	1	1550	1.9
			105	105											2.00	110	0.25	1.5	435	
200	30-90 60-160 140-280	80-140 or 130-200	99	102	99	117	32	20-44	90	19	17	M6	14	3.0	2.80	191	0.25	1.5	2040	2.2
			111	114											3.00	140	0.30	2	610	
300	100-200 150-240 220-400	120-180 or 180-300	114	117	120	132	41	25-56	110	23	20	M8	18	5.0	5.50	501	0.25	1.5	3750	2.2
			128	131											6.00	295	0.30	2	1050	
500	80-200 200-350 320-600	60-150 100-300 250-500	123	127	135	155	41	25-60	123	25	22	M8	25	6.5	11.00	510	0.30	2	2500	2.2
			136	140											12.80	500	0.35	2.5	840	
800	400-650 650-850 600-900	200-400 or 450-800	151	151	152	177	49	30-60	133	31	20	M10	36	9.0	20.00	780	0.35	2.5	2000	2.2
1500	600-800 700-1200 1000-1800	1250-1500	175	184	174	187	61	35-70	157	30	26	M12	70	16.3	42.00	1304	0.35	2.5	3600	3
2500	1500-2000 or 2000-2500	on request	245		240		80	50-100	200	37		M16	120	31	257	3400	0.35	2.5	6070	3

A^F, B^F, F^F = full disengagement

Model SK 5

TORQUE LIMITER

press-fit version, with clamping hub, for blind mounting

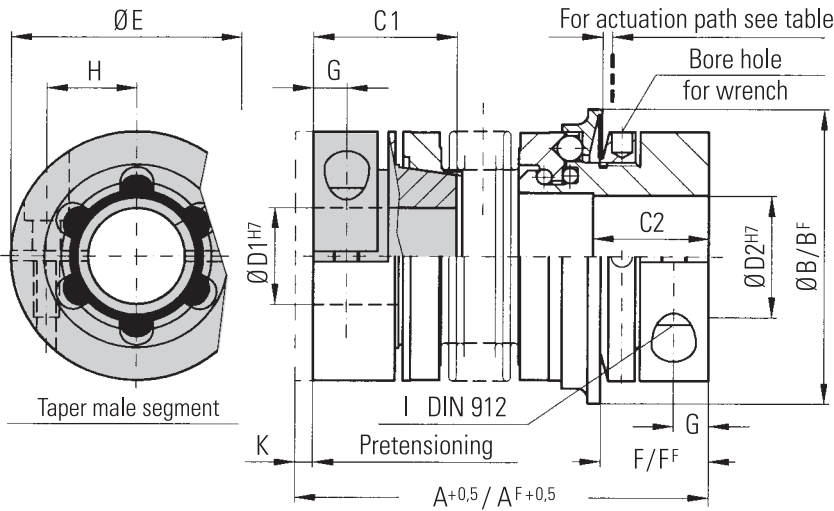

Press-fit precision torque limiters

Material:

Bellows made of highly elastic stainless steel
 Safety section: High strength hardened steel.
 Tapered segment: Glass fibre-reinforced plastic
 Hub material: up to series 80 aluminium from series 150 steel

Design:

1 side clamping hub with screw DIN 912
 1 side clamping hub with backlash-free, tapered press-fit connection

Temperature range: - 30°C to + 100 ° C

Speed after disengagement: Dependent on set disengagement torque

Backlash: Absolutely backlash free as a result of the frictional clamp connection and the patented R+W principle

Ordering specifications: see page 11

Optional sealed version for wash down and foodservice application. See page 16.

TECHNICAL INFORMATION

Single-position • Multi-position • Load holding • Full disengagement

Series	Adjustable range possible from - to	Adjustable range possible from - to	Overall length +0,5 inserted (mm)	Overall length +0,5 (full disengagement) (mm)	Outer diameter of actuation ring (mm)	Outer diameter of actuation ring (full disengagement) (mm)	Fit length (mm)	Fit length (mm)	Inner diameter from \varnothing to $\varnothing H7$ (mm)	Outer diameter from \varnothing to $\varnothing H7$ (mm)	Distance (mm)	Distance (full disengagement) (mm)	Distance between centers (mm)	DIN 912 screws (mm)	Tightening torque (mm)	Pretensioning, approx. (mm)	Axial recovery of coupling max. (mm)	Approx. weight (Nm)	Moment of inertia (N)	Torsional stiffness (N)	Lateral stiffness (kg)	Angular misalignment (10 ⁻³ kgm ²)	Lateral misalignment (10 ⁻³ Nm/rad)	Lateral spring stiffness (N/mm)	Actuation path (mm)	
	T_{KN}	T_{KN}	A	A ^F	B	B ^F	C ₁	C ₂	D ₁	D ₂	E	F	FF	G	H	I	K	J _{ges.}	C _T							
2	0.2-1.5 or 0.5-2	0.5-2	48	48	29	32	16	13	4-12	4-12	25	13	12	4	8	M3	2	0.2 to 0.7	8	0.07	0.01	2.8	0.15	1	40	0.8
			54	54														0.01			2.1	0.20	1.5	30		
4.5	1-3 or 3-6	2.5-4.5	60	60	35	42	19	16	5-14	4-14	32	15	14	5	10	M4	2.5	0.2 to 0.7	15	0.2	0.02	7	0.20	1.5	290	0.8
			68	68														0.02			5	0.25	2	45		
10	2-6 or 4-12	4-10	70	70	45	51.5	21	16	5-20	5-20	40	17	16	5	15	M4	4	0.2 to 1.0	25	0.3	0.06	9	0.20	1.5	280	1.2
			79	79														0.07			9	0.30	2	145		
15	5-20	7-15	76	76	55	62	28	22	8-22	8-26	49	19	19	6.5	17	M5	8	0.2 to 1.0	20	0.4	0.10	20	0.15	1	475	1.5
			83	83														0.15			15	0.20	1.5	137		
30	10-25 or 20-40	8-20 or 16-30	89	89	65	70	33	27	10-25	10-30	55	24	22	7.5	19	M6	15	0.5 to 1.0	50	0.6	0.27	39	0.20	1	900	1.5
			97	97														0.32			28	0.25	1.5	270		
60	10-30 or 25-80	10-30 or 30-60	105	105	73	83	39	31	12-32	12-32	66	30	29	9.5	23	M8	40	0.5 to 1.0	70	1.4	0.75	76	0.20	1	1200	1.7
			115	115														0.80			55	0.25	1.5	420		
80	20-70 or 30-90	20-60 or 40-80	115	117	92	98	43	35	14-38	14-42	81	31	31	11	27	M10	50	0.5 to 1.0	48	2	1.80	129	0.20	1	920	1.9
			127	129														1.90			85	0.25	1.5	290		
150	40-170	80-150	116	118	92	98	43	35	14-38	14-42	81	31	30	11	27	M10	70	0.5 to 1.0	82	2.4	2.50	175	0.20	1	1550	1.9
			128	130														2.80			110	0.25	1.5	435		
300	100-200 or 150-240 or 200-320	120-200 or 180-300	143	146	120	132	52	42	30-56	30-60	110	35	36	13	39	M12	130	0.5 to 1.5	157	4	6.50	501	0.25	1.5	3750	2.2
			157	160														7.00			295	0.30	2	1050		
500	80-200 or 200-350 or 300-500	60-150 or 100-300 or 250-500	166	170	135	155	61	52	35-60	35-60	123	45	43	17	41	M16	200	0.5 to 2	140	8.5	13.00	510	0.30	2	2500	2.2
			180	184														17.00			500	0.35	2.5	840		

A^F, B^F, F^F = full disengagement

Caution! If the setted torque exceeds the series torque please contact the manufacturer.

Model SK 5

Design details

Six self-centering, tapered drive projections (2) have been formed into the conical element, which has been molded onto an aluminium hub (1).

The six axially arranged projections are configured conically in a longitudinal direction (3). The mating-piece consists of a metal bellow with a female tapered mounting segment (4).

Absolutely backlash-free torque transmission is ensured due to the axial pretensioning (5) of the metal bellows during mounting. This slight pretensioning has no negative influence on the operation of the metal bellows or on the shaft bearing.

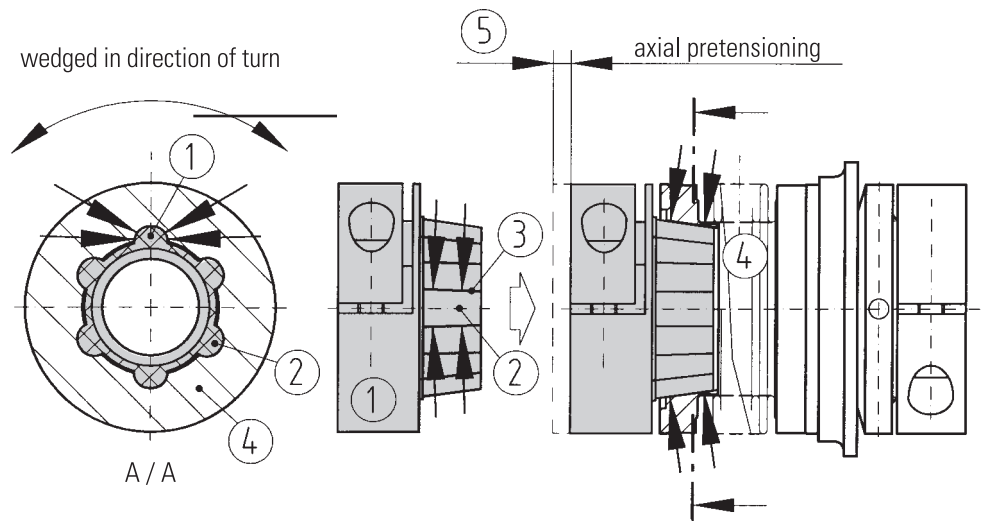

Possible applications for backlash-free, press-fit torque limiter SK 5

Applications with limited accessibility.

The dismantling of a single-piece coupling is too labor intensive.

The press fit design allows the complete drive unit to be removed by simply pulling it out when servicing is required.

Dismantling the coupling is possible without loosening the hub fastening screws. Therefore, clamping screw access holes are not required.

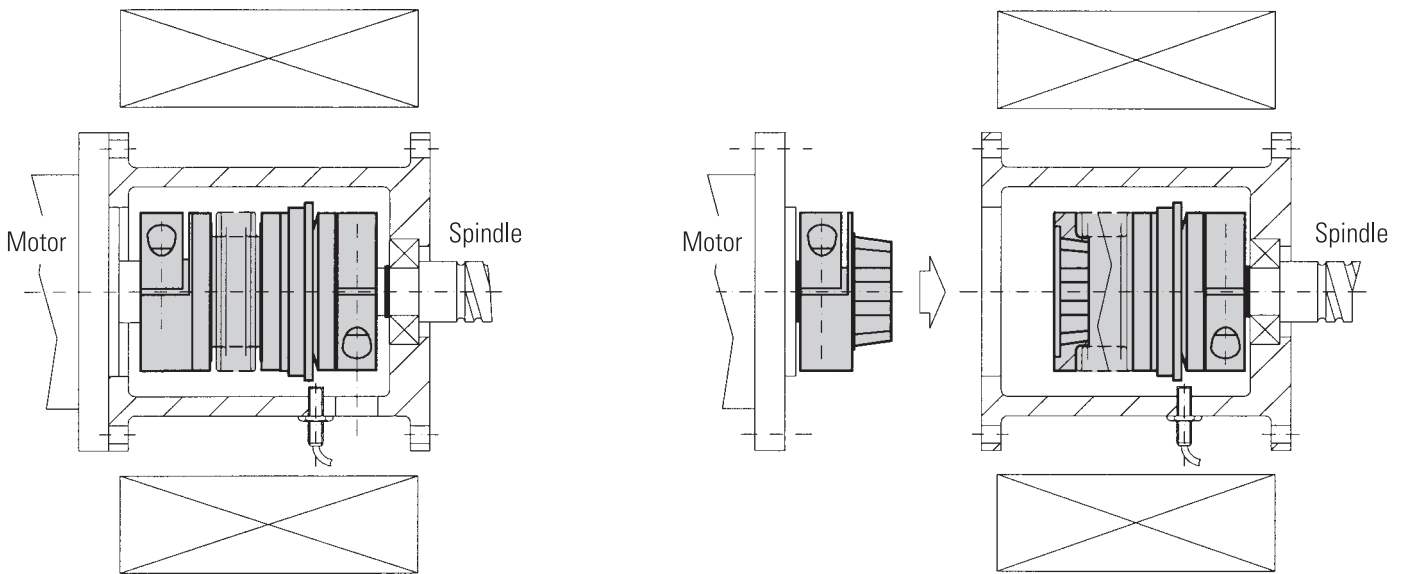

Ordering specifications for SK2, SK3, and SK5:

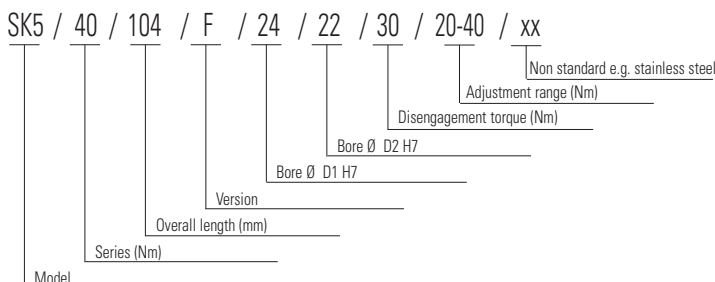

Possible versions:

- W = single position
- D = multi position
- G = Load holding
- F = Full disengagement

Accessories

Torque adjusting wrench DIN 1816

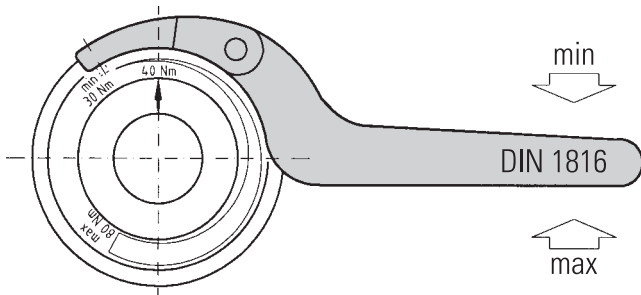

Small coupling sizes do not require a wrench. The adjusting nuts for series 2, 4.5, 10 can be adjusted with a bolt.

Coupling series			Wrench
15			Order-No. 60/4
20/30	40/60	80/150	Order-No. 90/5
200			Order-No. 90/6
300			Order-No. 155/6
500	8000		Order-No. 155/8
1500			Order-No. 230/8

Mechanical switch for Emergency Cut-Off (appropriate from series 10 on)

Dimensions

(Order-No. 618.6740.425)

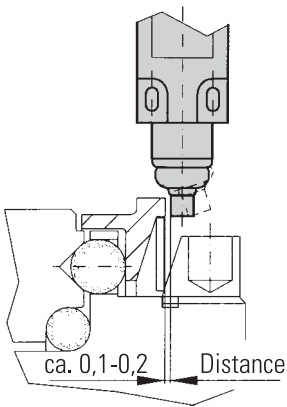

Technical data

Max. voltage: 500 V AC
Max. constant current: 10 A
Protective system: IP 65
Contact system: Opener (forced separation)
Ambient temperature: -30 - +80 °C
Housing: glass-fibre reinforced thermoplast
Actuation: Tappet (metal)
Switch diagram:

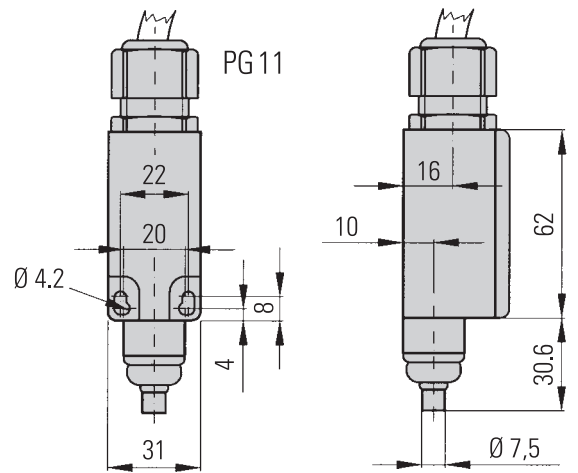

The actuation tappet should be put as close as possible to the actuation ring of the torque limiter (approx. 0.1-0.2)

Important: Upon assembly, it is absolutely necessary to check the function of the switch 100%.

Proximity switch for Emergency cut-off

Dimensions

(Order-No. 650.2703.1)

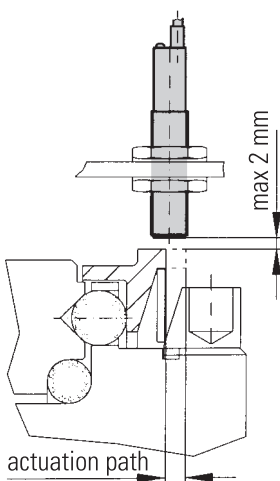

Technical data

Voltage: 10-30V DC
Output current: 200 mA
Switch frequency: 800 Hz
Temperature range: -25 to 80 °C
Protective System: IP 67
Switch Type: normally open
Max. detection gap: 2 mm
Switch diagram:

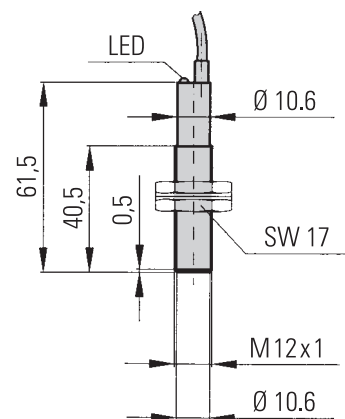

Important: Upon assembly, it is absolutely necessary to check the function of the switch 100%.

General function

R+W torque limiting couplings are ball detent style overload couplings. They protect drive and driven mechanical components from damage associated with torque overloads. Backlash free torque transmission is accomplished by a series of steel balls (4) nested in hardened detents (5). See figure 1. Disc springs push against an actuation ring (3) keeping the balls nested. The disengagement torque is adjustable by means of an adjustment ring (1). In the event of an overload, the actuation ring moves axially allowing the balls to come out of the detents separating the drive and driven elements. The movement of the actuation ring can be sensed by means of a mechanical switch or proximity sensor triggering the drive to shut down.

Single-position / Multi-position

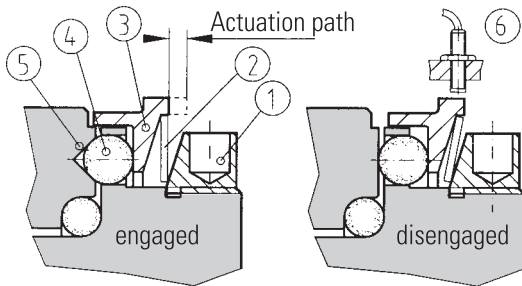

In a torque overload, for the single-position design (standard) and multi-position design, the spring disengages to allow the balls to come out of their detents separating the drive and driven elements. Very low residual spring pressure remains so that the coupling will re-engage once the torque is reduced below the overload setting. See diagram 1 too.

Re-engagement may only be effected at low speed.

Full-disengage

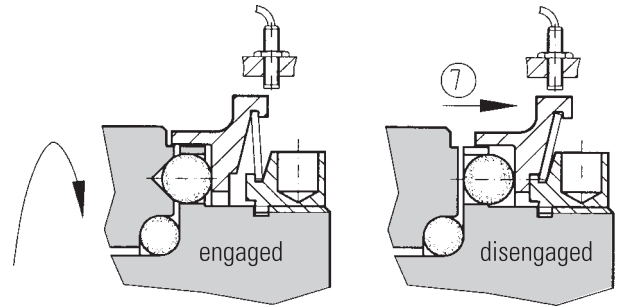

With this design, when a torque overload is detected, the disc spring completely flips over and places no residual spring pressure on the actuation ring. The drive and driven elements are completely separated.

Re-engagement of the coupling is not automatic and must be performed manually (Figure 3).

Full-disengage

Re-engagement of the Full-disengage design

The R+W full-disengage torque limiting coupling can be re-engaged in six different positions or every 60 degrees with low "press-in" force (E). Marks on the actuation ring and body (13) of the coupling must line up and indicate the re-engagement points.

CAUTION: Re-engagement should only be performed when the coupling is still and not rotating!

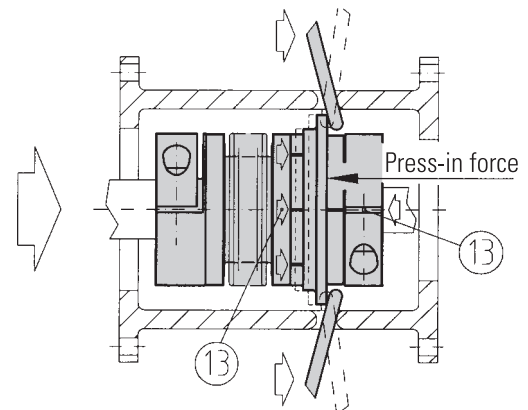

max. misalignments SK 2 - SK 5

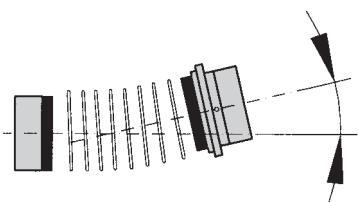

Angular misalignment ΔKw

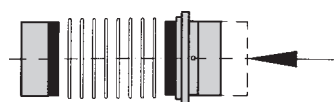

Axial misalignment ΔKa

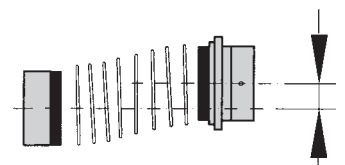

Lateral misalignment ΔKr

CAUTION:

Exact alignment of the R+W metal bellow coupling considerably increases the service life of the coupling. Reducing or eliminating lateral misalignment eliminates the radial loading of the adjacent bearings, increasing service life and reducing heat. For drives running at high speed it is recommended to align the coupling with a dial indicator.

Max. misalignment values see table. Axial misalignment between 1-2 mm (max.).

Mounting-instructions

- All torque limiters are supplied to ISO bore tolerance grade H7. For models SK1 to SK 5 the fit tolerance of the hub/shaft connection must be between 0.01 and 0.05 mm.
- Ensure that the coupling mounts smoothly onto the shaft prior to final installation.
- Lightly oil the shaft prior to installation. Do not use sliding grease, or oils and grease with molybdenum disulfide or other high-pressure additives. Any keyways in the shaft will not affect the functioning of the clamped connection.

Model SK1 / SKP

Model SK1 has an integrated bearing ① for support of the attached component (for example a pulley or sprocket wheel).

Do not exceed the maximum radial force ② (see table)

By centering the load between the dimension ⑤, addition separate bearing support is not required.

For offset mounting, additional bearings are required.

This is recommended, for example, if the attached component has a very small diameter or the drive element has a very large width.

Depending on the installation situation, ball bearings, needle bearings or bushings may be used.

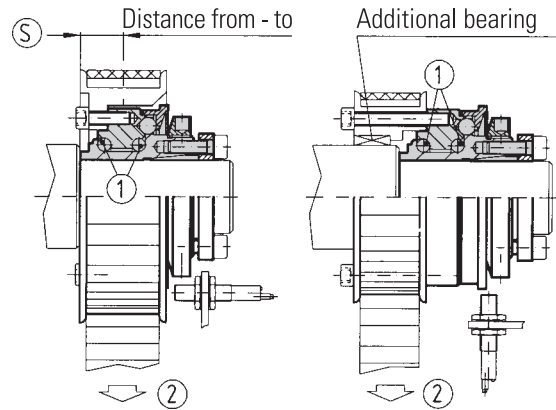

Series max. (N)	2	4,5	10	15	20/30	40/60	80/150	200	300	500	800	1500
Radial load capacity, max. (N)	100	200	500	1400	1800	2300	3000	3500	4500	5600	8000	12000
⑤ from-to	5-8	6-10	6-12	7-14	8-18	8-18	12-20	12-22	12-23	12-25	14-34	20-42

Mounting and dismounting: Models SK 1 and SKP

SKP with key

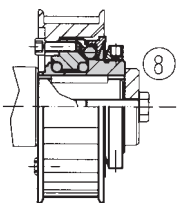

Mounting:

Slide the coupling onto the shaft. Lock it in position, with an end plate (8) for example.

Dismounting:

Remove the end plate and slide the coupling off the shaft using an appropriate tool.

SK 1 with clamping hub

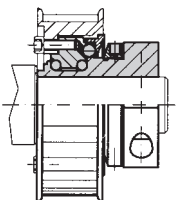

Mounting:

Slide the coupling onto the shaft to the proper axial position. Using a torque wrench tighten the clamp screw to the proper tightening torque as indicated.

Series 2-10 page 7, series 15 and higher see SK 2 page 8.

Dismounting:

Simply loosen the clamp screw and remove the coupling.

SK 1 with tapered bushing

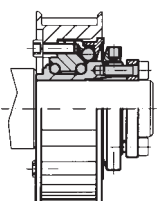

Mounting:

Slide the coupling onto the shaft to the proper axial position. Using a torque wrench, uniformly tighten the clamping screws using a cross-wise tightening pattern until all the clamping screws are evenly tightened to the correct tightening torque as given on page 6. While tightening the coupling may move slightly towards the tapered bushing.

CAUTION: Further tightening of the clamping screws may destroy the tapered bushing connection.

Dismounting:

Loosen the clamping screw. Insert the three jack screws into the taped holes on the tapered segment apply even pressure to remove the tapered segment. Remove the coupling.

Mounting-instructions

SK 2 with clamping hub

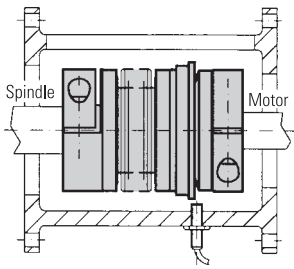

Mounting:

Prior to mounting make sure that the shaft to be connected do not exceed the angular or lateral misalignment limits for the coupling size to be used. This data can be found in the catalog. Slide the coupling on the first shaft end to the proper axial position. Using a torque wrench, tighten the clamp screw to the correct tightening torque as indicated (page 8). Insert the second shaft into the other end of the coupling to the proper axial position. Make sure that the coupling is free of any axial forces before tightening. Tighten the clamp screw as above using a torque wrench.

Dismounting:

Simply loosen the clamp screw and remove the coupling.

SK 3 with tapered bushing

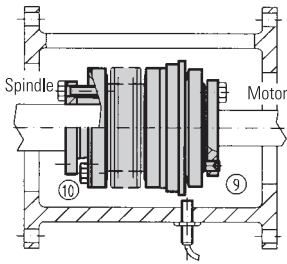

Mounting:

Prior to mounting make sure that the shaft to be connected do not exceed the angular or lateral misalignment limits for the coupling size to be used. This data can be found in the catalog. Slide the coupling onto the first shaft to the proper axial position. Using a torque wrench, uniformly tighten the clamping screws using a cross-wise tightening pattern until all the clamping screws are evenly tightened to the correct tightening torque (see page 9).

Dismounting:

Loosen the clamping screws. Use the three jackscrews conveniently mounted in the taper segment to evenly back out the tapered segment. Remove the coupling.

SK 5 with press-fit tapered clamping hubs

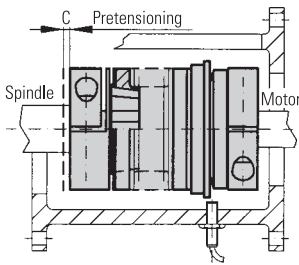

Mounting:

Prior to mounting it is necessary to consider the overall length of the assembled coupling. The press-fit coupling requires a specific pre-tensioning (C) between the two coupling halves to ensure backlash free operation. Mount the "female" coupling half containing the bellows onto the first shaft end to the proper axial position. Using a torque wrench tighten the clamp screw to the proper tightening torque. Mount the "male" coupling segment onto the second shaft end. The proper axial position is when the two couplings come together and coupling is compressed by the proper pre-tension distance (C). See Table 2. When the coupling segment is properly positioned tighten the clamp screw to the proper torque.

Dismounting:

Pull the coupling apart. Simply loosen the clamp screws and remove the coupling from the shaft.

Disengagement torque setting

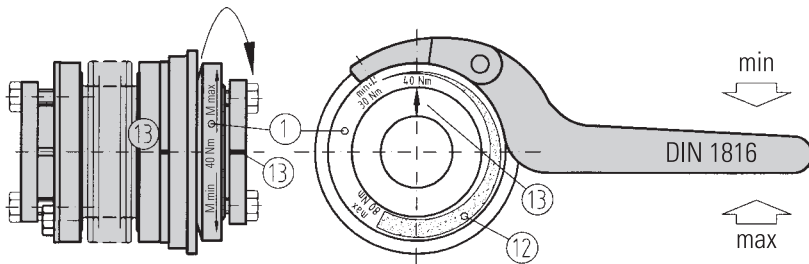

With SK 2/5 couplings, the groove of the clamping hub serves as a marking (3)

R+W torque limiters are factory set to the customer specified disengagement torque, which is marked onto the coupling. The adjustment range (min/max) is also marked on the adjustment ring. The customer can adjust the disengagement torque as long as it falls into the range indicated on the adjustment ring.

The adjustment range may not be left during setting.

To adjust the disengagement torque, loosen the locking screws (11) and rotate the adjustment ring using a spanner wrench to the desired new setting. Tighten the locking screws and test the coupling.

CAUTION: R+W torque limiters incorporate disc springs that exhibit a special spring characteristic. It is important to stay in the max-min range of the courding.

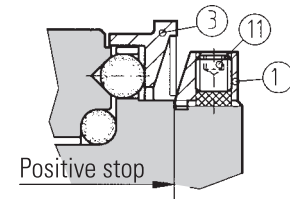

- 1 adjusting nut
- 11 fastening screw
- 3 steel actuation ring
- 12 adjustment range
- 13 marking

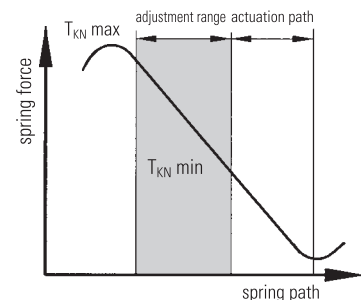

Disengagement behaviour

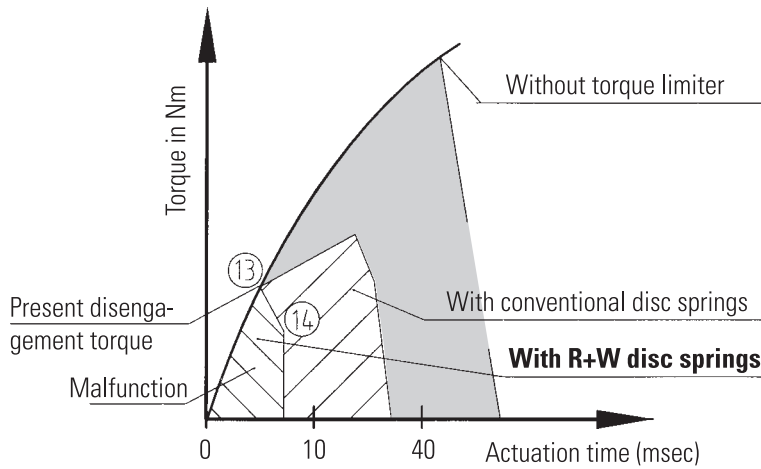

Spring characteristic

Degressive spring characteristic

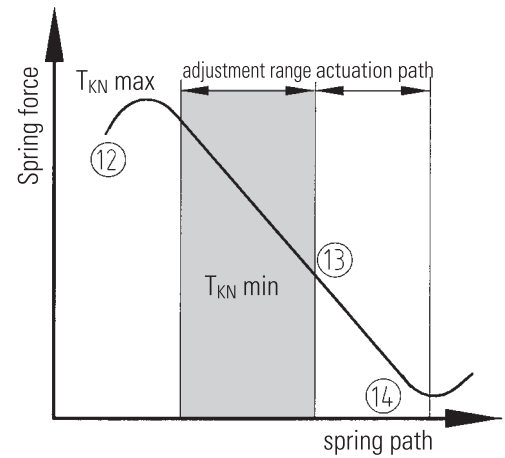

Spring package:

R + W torque limiters function by means of a disc spring with a degressive characteristic (12) developed exclusively for this application. Upon the couplings actuation, this characteristic (13) brings about an immediate drop in the torque (14) and an interruption of the force flux.

The spring force of the disc spring drops to a lower value after the disengagement process.

This advantage guarantees extremely short actuation times (1-3 ms), low wear and very low residual friction (between 2-5 %).

Speed:

The service life of the coupling is essentially determined by the number of rotations after disengagement.

Wear:

No wear occurs during engaged operating condition. In the event of an overload the drive should be stopped through a mechanical limit switch or proximity switch immediately.

Maintenance:

When properly engaged, the torque limiters are wear free, and therefore require no maintenance. The ball detent mechanism within each coupling is permanently lubricated. Prior technical approval is suggested, for applications using our products other than specified.

Seal:

Optional a sealing of the coupling is possible:

Features:

- protection from dirt and liquid contamination
- appropriate for food service and light washdown environments
- clean room applications
- No escape of grease possible

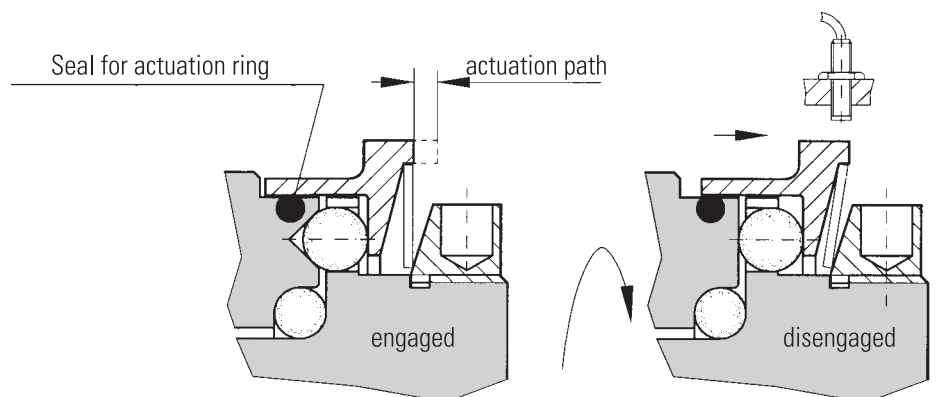

According to disengagement torque

As a rule torque limiters are rated according to the required disengagement torque, which must be greater than the torque that is necessary for regular machine operation.

The disengagement torque of the torque limiters is determined as a rule in accordance with the drive specifications.

The following calculation has proven itself as a rule of thumb solution:

$$T_{KN} \geq 1,5 \cdot T_{AS} \text{ (Nm)}$$

or

$$T_{KN} = 9550 \cdot \frac{P_{AN}}{n} \times 1.5 \text{ (Nm)}$$

$$\begin{aligned} T_{KN} &= \text{rated torque of coupling} && \text{(Nm)} \\ T_{AS} &= \text{peak torque of motor} && \text{(Nm)} \end{aligned}$$

$$\begin{aligned} T_{KN} &= \text{rated torque of coupling} && \text{(Nm)} \\ P_{AN} &= \text{drive power} && \text{(kw)} \\ n &= \text{speed of drive} && \text{(rpm)} \end{aligned}$$

According to acceleration torque (start-up at no load)

$$T_{KN} = \alpha \cdot J_L = \frac{J_L}{J_A + J_L} \cdot T_{AS} \cdot S_A \text{ (Nm)}$$

S_A = jerk or load factor
 $S_A = 1$ (uniform load)
 $S_A = 2$ (non-uniform load)
 $S_A = 3$ (jerky load)

Values for $S_A = 2-3$ are usual for servo drives on machine-tools.

$$\begin{aligned} T_{KN} &= \text{rated torque of coupling} && \text{(Nm)} \\ \alpha &= \text{angular acceleration} && \left(\frac{1}{s^2}\right) \\ \alpha &= \frac{\omega}{t} = \frac{\pi \cdot n}{t \cdot 30} \\ t &= \text{acceleration time} && \text{(s)} \\ \omega &= \text{angular speed in} && \text{(s-1)} \\ n &= \text{speed of drive} && \text{(rpm)} \\ J_L &= \text{moment of inertia on load side} && \text{(kgm}^2\text{)} \\ J_A &= \text{moment of inertia on driving side} && \text{(kgm}^2\text{)} \\ T_{AS} &= \text{peak torque of motor} && \text{(Nm)} \end{aligned}$$

According to acceleration and load torque

$$T_{KN} = \alpha \cdot J_L + T_{AN} = \left[\frac{J_L}{J_A + J_L} \cdot (T_{AS} - T_{AN}) + T_{AN} \right] \cdot S_A \text{ (Nm)}$$

S_A = jerk or load factor
 $S_A = 1$ (uniform load)
 $S_A = 2$ (non-uniform load)
 $S_A = 3$ (jerky load)

Values for $S_A = 2-3$ are usual for servo drives on machine-tools.

$$\begin{aligned} T_{KN} &= \text{rated torque of coupling} && \text{(Nm)} \\ \alpha &= \text{angular acceleration} && \left(\frac{1}{s^2}\right) \\ \alpha &= \frac{\omega}{t} = \frac{\pi \cdot n}{t \cdot 30} \\ t &= \text{acceleration time} && \text{(s)} \\ \omega &= \text{angular speed in} && \text{(1/s)} \\ n &= \text{speed of drive} && \text{(rpm)} \\ J_L &= \text{moment of inertia on load side} && \text{(kgm}^2\text{)} \\ T_{AN} &= \text{load torque} && \text{(Nm)} \\ J_A &= \text{moment of inertia on driving side} && \text{(kgm}^2\text{)} \\ T_{AS} &= \text{peak torque of motor} && \text{(Nm)} \end{aligned}$$

The selection of torque limiters

According to feed force

Spindle drive

$$T_{AN} = \frac{s \cdot F_V}{2000 \cdot \pi \cdot \eta} \quad (\text{Nm})$$

T_{AN}	= load torque	(Nm)
s	= spindle pitch	(mm)
F_V	= feed force	(N)
η	= spindle efficiency	(N)

Timing belt drive

$$T_{AN} = \frac{d_0 \cdot F_V}{2000} \quad (\text{Nm})$$

T_{AN}	= load torque	(Nm)
d_0	= pinion dia. (pulley)	(mm)
F_V	= feed force	(N)

According to resonant frequency (SK 2 / 3 / 5 with bellows attachment)

Usually high resonant frequencies of the couplings are required in order to make high acceleration values possible and avoid any vibration excitation.

For the purpose of calculation the drive is reduced to a 2 mass system.

$$f_e = \frac{1}{2 \cdot \pi} \sqrt{C_T \times \frac{J_{Masch} + J_{Mot}}{J_{Masch} \cdot J_{Mot}}} \quad (\text{Hz})$$

C_t	= torsional stiffness of the coupling	(Nm/rad)
$J_{Masch.}$	= moment of inertia of machine (spindle + slide + workpiece + half of coupling)	(kgm ²)
$J_{Mot.}$	= moment of inertia of motor (motor's rotor + half of coupling)	(kgm ²)
f_e	= Resonant frequency of a two mass system	(Hz)

According to torsional stiffness (SK 2/3/5 with bellows attachment)

Transmission errors due to a torsional stress on the metal bellows:

$$\varphi = \frac{180}{\pi} \cdot \frac{T_{AS}}{C_T} \quad (\text{degrees})$$

φ	= angle of turn	(degrees)
C_t	= torsional stiffness of coupling	(Nm/rad)
T_{AS}	= peak torque of motor	(Nm)

According to the function system

load holding version: On SK1 / SKP models the load holding version has a double load safety margin. Ensure that models with bellows (SK2, 3 and 5) are of adequate size. The blocking load in this case should not exceed the nominal torque of the coupling.

About R+W

Quality an know-how for couplings in servo, NC and stepping motor systems. The demands on drive technology have dramatically and steadily increased in the last few years. Our company **R+W** is proud to have reached a leading market position within the same few short years and we continue to work hard in the areas of design and technical development to stay there. **R+W** has representatives in 23 countries all over the world and is opening more branches every year. Our range of high-quality precision couplings meets the needs of the most demanding applications. But for our technical staff this is not enough. We are constantly developing, new solutions, new designs, new possibilities. We want you to contact us, to give us the opportunity to create a solution and to earn your business. Each person on the **R+W** staff knows that quality comes from his or her personal engagement with, and listening to, the customer.

Benefit from our quality and efficiency. We are ISO 9001 certified. Our production and customer service department have been organized to maximize efficiency and minimize delivery time. Extensive quantities of component inventory are kept on hand to ensure the quickest possible delivery, often within one day. Special designs are a major part of our business and are immediately processed, designed and built. **R+W** also has developed proprietary software to calculate resonant frequencies and aid in the design of extremely long and specialized ZA series couplings. **R+W** continues to reinvest to ensure that our couplings remain innovative to improve their efficiency and operating dependability with your applicatons.

Special low cost rust protection process

Corrosion protection which is equivalent to that of galvanized or chrome-plated surfaces is available. The positive features of this include good resistance to wear and corrosion.

The parts are resistant to a salt spray test pursuant to DIN 50021 for a period of 140 hours.

This process represents a genuine, low cost alternative to expensive stainless steel materials.

Couplings with this surface treatment have been used for many years by well-known companies in the food industry.

Versions in explosion-protected design

All models can be supplied in an explosion-protected design to order without any change in dimensions.

DXF + 3D files

The complete product range can be supplied on CD-ROM in DXF and DWG files. This allows the files to be imported into design programs easily. 3 dimensional drawings of the couplings are also available.

Download

All the drawings can be down loaded directly from our homepage www.rwcouplings.com.

DIN ISO 9001

Quality awareness is a high priority at R+W.

The introduction of DIN ISO 9001 has meant the refinement of quality procedures and the appropriate documentation.

In a one-year preparation peroid, the ISO 9001 quality system was produced and certified on 4 March 1997.

Constant monitoring and improvement of the system ensures a technically superior product with a quality standard second to none.



The R+W product range

Experience and
Know-how
for your
special
requirements.



TGA-ZQ-031/95-00
Registrierungs-Nr. 9605022

The information mentioned in this document is based on our present knowledge and experiences and does not exclude the manufacturer's own substantial testing of the equipment. So this is no obligatory assurance even with regard to protection rights of Third Parties. The sale of our products is subject to our General Conditions of Sale and Delivery.

R + W Antriebselemente GmbH
Alexander-Wiegand-Straße 8
D-63911 Klingenberg/Germany
Tel. +49-(0)9372 – 9864-0
Fax +49-(0)9372 – 9864-20
info@rw-kupplungen.de
www.rwcouplings.com

R+W
COUPLING TECHNOLOGY

TORQUE LIMITERS Series SK

From 0.1 – 2,500 Nm
Bore diameters 4 – 70 mm
Available as a single position, multi-position, load holding, or full disengagement version
Single piece or press-fit design



BELLOW COUPLINGS Series BK

From 15 – 10,000 Nm
Bore diameters 10 – 180 mm
Single piece or press-fit design



BELLOW COUPLINGS ECONOMY CLASS Series BKL

From 2 – 500 Nm
Bore diameters 4 – 62 mm



LINE SHAFTS Series ZA/ZAe

From 10 – 4,000 Nm
Bore diameters 10 – 100 mm
Available up to 6 mtr. length



MINIATURE BELLOWS COUPLINGS Series MK

From 0.05 – 10 Nm
Bore diameters 1 – 28 mm
Single piece or press-fit design



SERVO-INSERT-COUPLINGS SERVOMAX Series EK

From 10 – 1,100 Nm
Shaft diameters 5 – 60 mm
backlash-free, press-fit design



LINEAR COUPLINGS Series LK

From 70 – 800 N
Thread M5 – M12



POLYAMID COUPLINGS MIKROFLEX Series FK 1

Rated torque 1 Ncm
Bore diameters 1 – 1.5 mm



compact and backlash free

TORQUE LIMITERS

Series SK · 0.1 – 2,500 Nm

with single-position re-engagement

Multi-position - Load holding - Full disengagement



R+W[®]
COUPLING TECHNOLOGY