

Nová generácia tlmičov rázu

MA 150

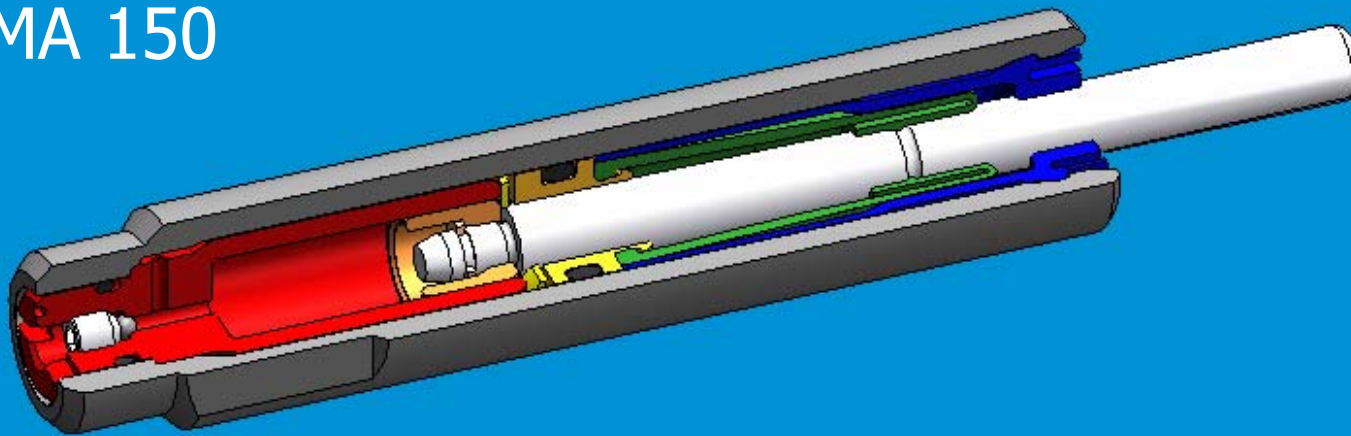

Nová generácia tlmičov rázu

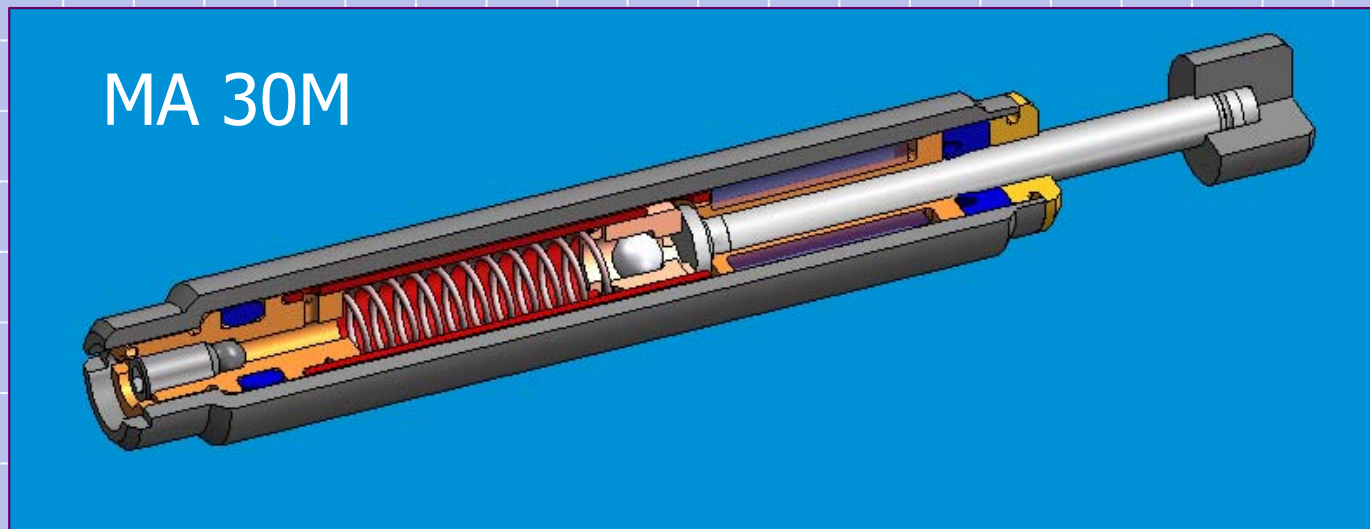

Nová generácia tlmičov rázu

MC 30M

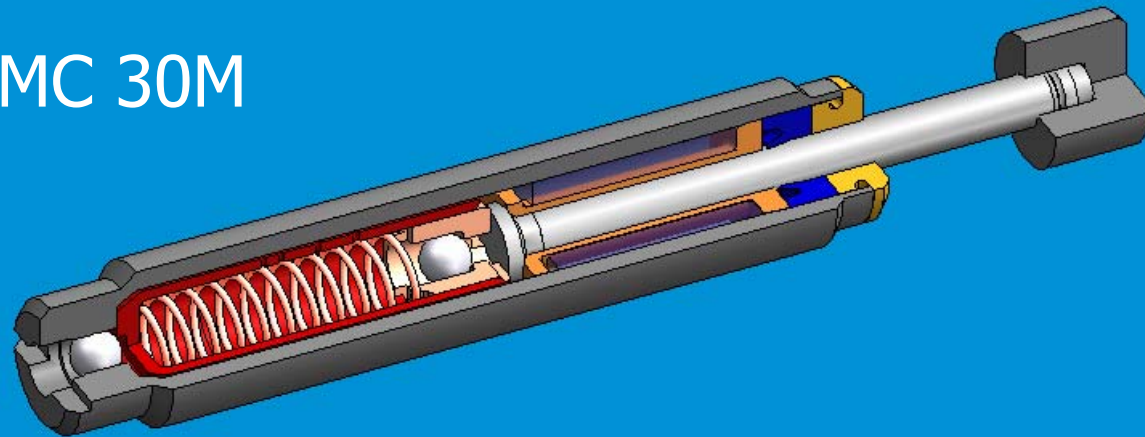

Nová generácia tlmičov rázu

MC 30M-Z

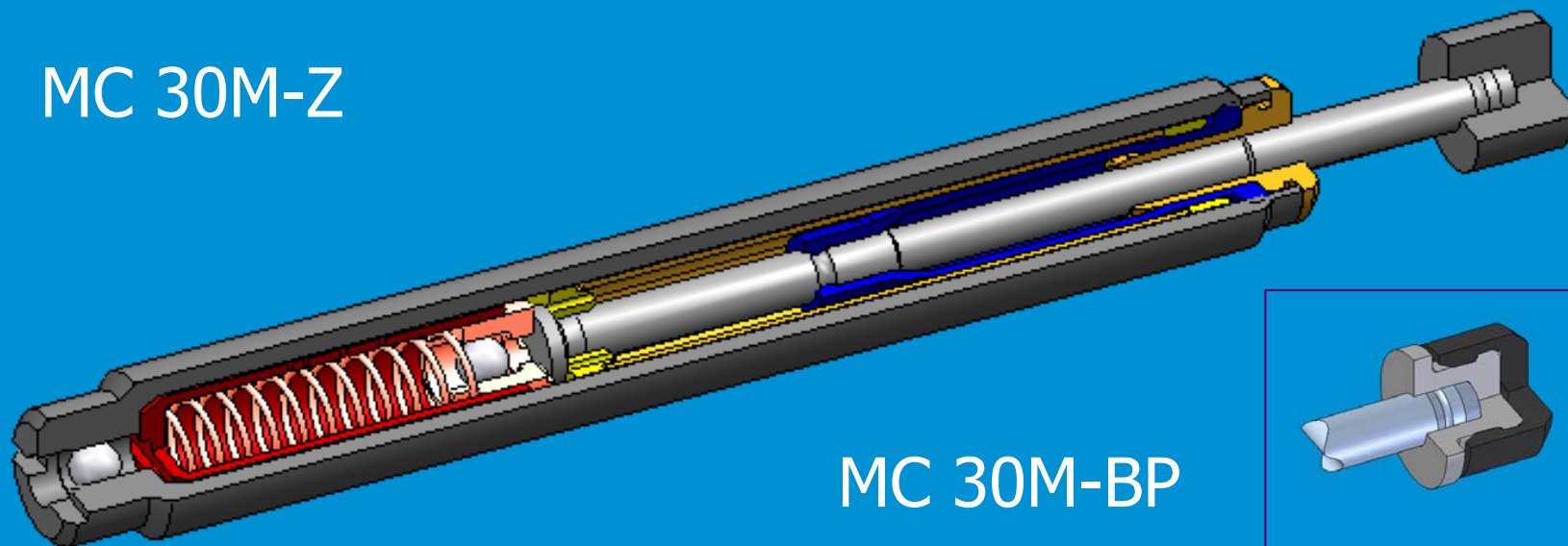

MC 30M-BP

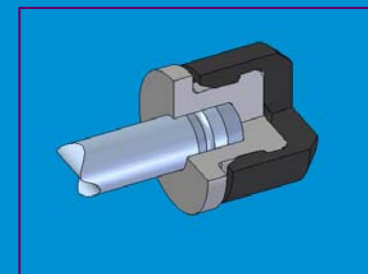

MA & MC 30M – Konštrukčné zmeny

MA 30M

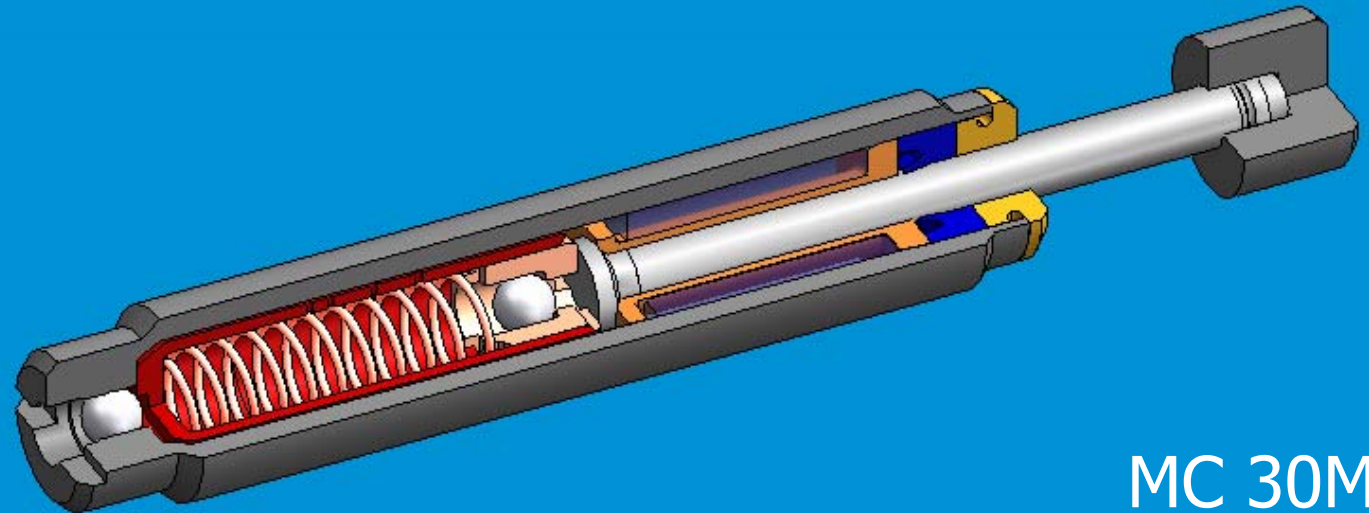
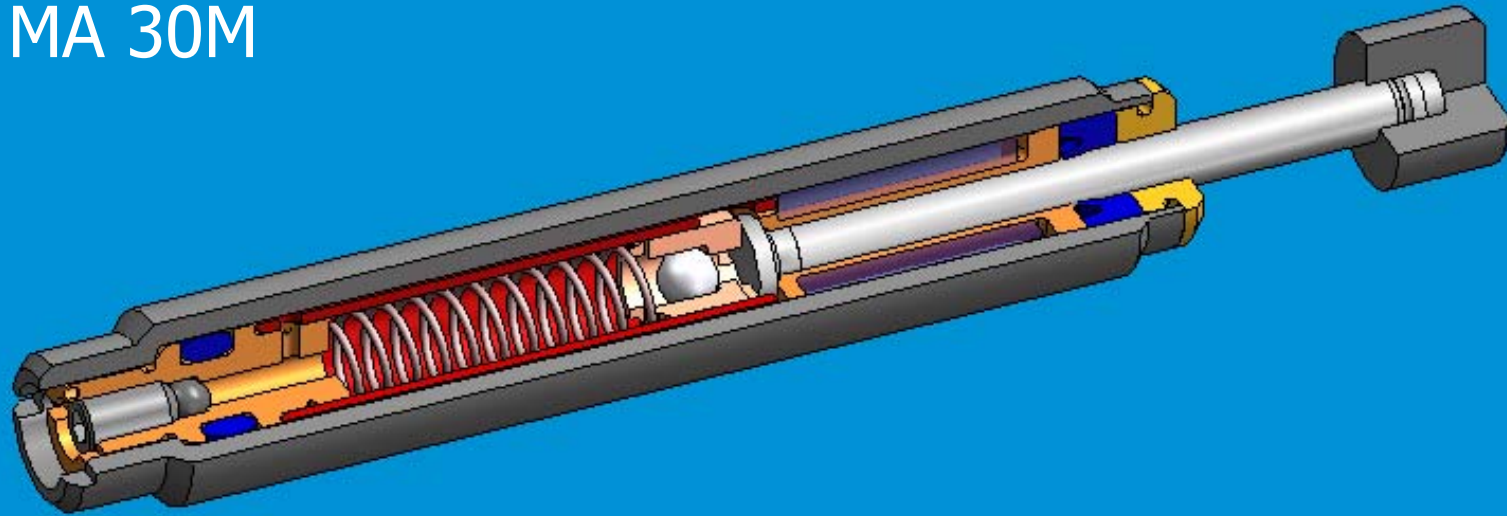

MC 30M

MA & MC 30M – Porovnanie

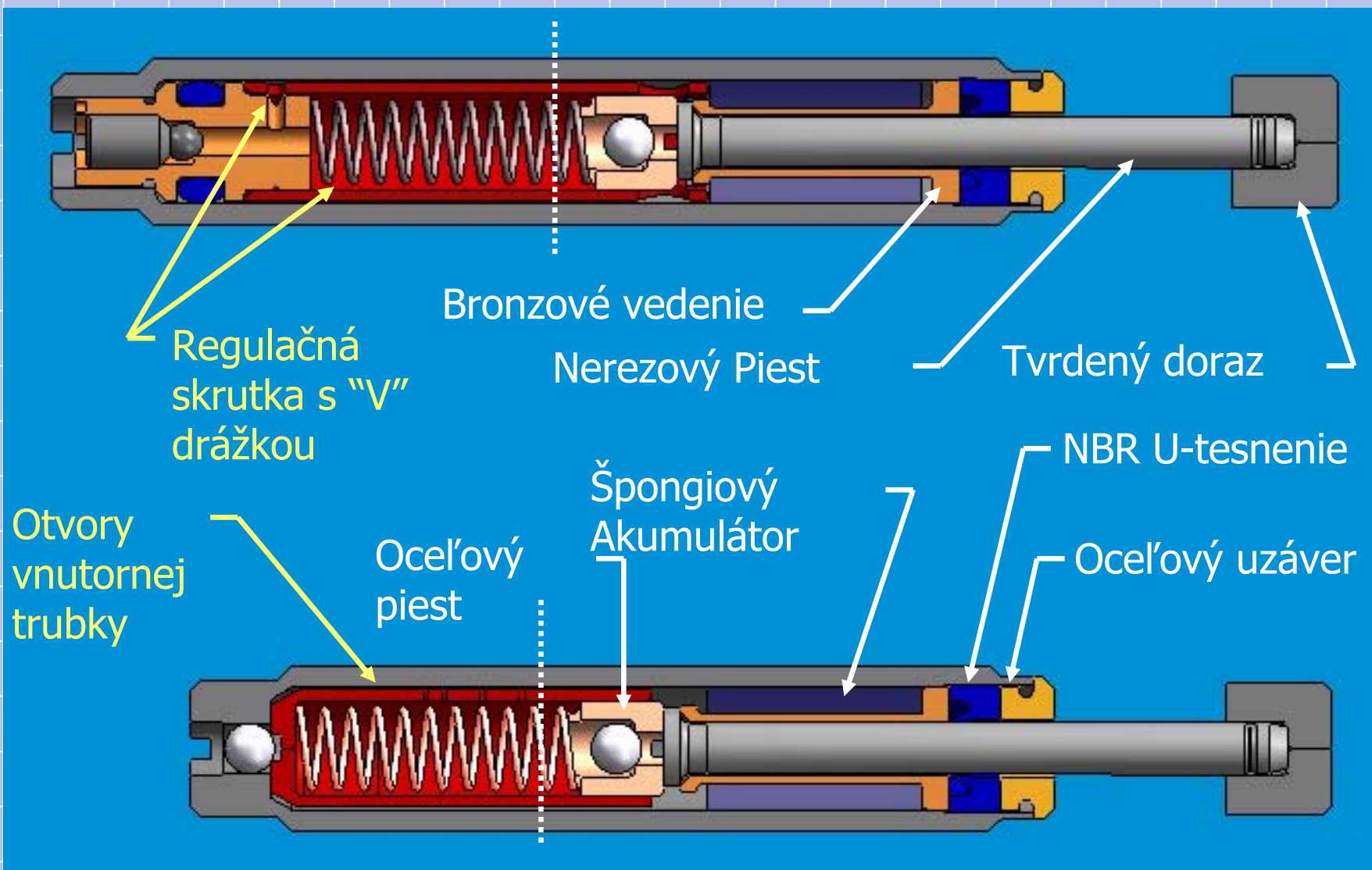

MA & MC 30M – technická špecifikácia

- ✓ M8x1 Model s W3 = 3.5 N-m
- ✓ Samo-Kompenzačný~Rozsah Efektívnej váhy:
 - ✓ 0,45 - 1,95 kg
 - ✓ 1,8 - 5,4 kg
 - ✓ 5 - 15 kg
- ✓ Nastaviteľný~Rozsah Efektívnej váhy: 0,2- 14,1
- ✓ 8 mm zdvih
- ✓ PP doraz štandard
- ✓ Zabudovaný pozitívny doraz
- ✓ Drážka pre skrutkovač

MA & MC 30M – Inštalačné rozmery

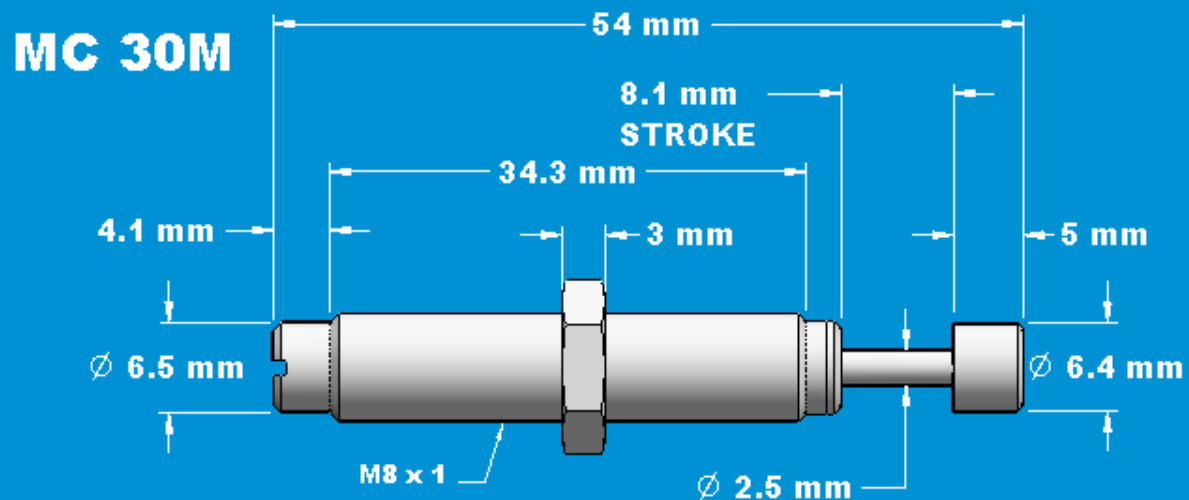
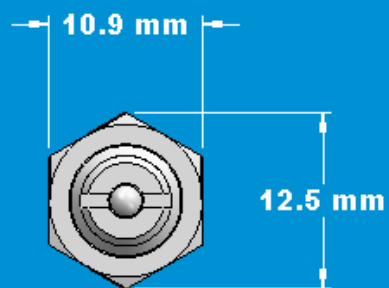
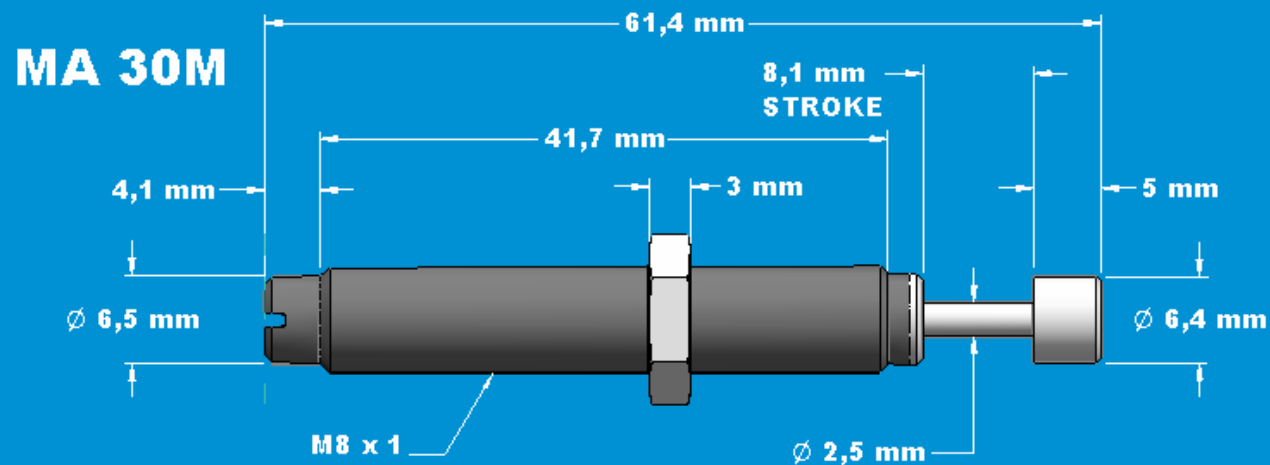
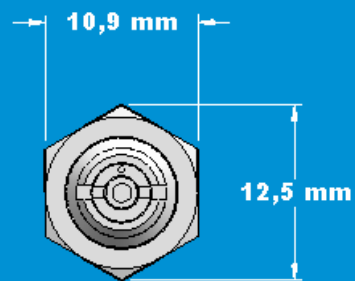

MA & MC 30M – Špecifikácia

Model	Závit	Zdvih (mm)	Dĺžka (mm)	Efektívna váha (kg)	(W3) Energia na zdvih (N-m)	(W4) Energia za hodinu (N-m/hr)	Vratná sila (N)	Vratný čas (secs)	Váha (kg)
MA 30M	M8x1.0	8	61,4	.23~15.0	3,5	5650	.89~4.45	0,3	0,009
MC 30M1	"	"	54.0	.45~1.95	"	"	"	"	"
MC 30M2	"	"	"	1.8~5.4	"	"	"	"	"
MC 30M3	"	"	"	5~15	"	"	"	"	"

Dodatočná Špecifikácia:

- ❖ Nárazová rýchlosť ~ 0,7 to 4,45 m/s
- ❖ Pracovná Teplota ~ 0 to 66° C
- ❖ Olej Typ ~ Ace Oil #5
- ❖ PP doraz štandard,
- ❖ Integrovaný mechanický doraz zabudovný na začiatku tmiča
- ❖ Drážka pre reguláciu skrutkovačom

MA & MC 30M – +Nový typ dostupný čoskoro



BP
doraz

Energia
50% W3

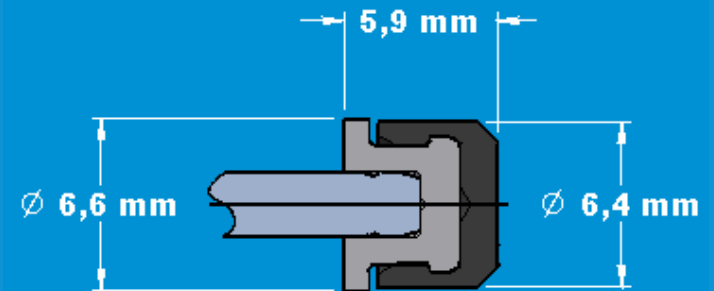

-Z
Verzia

